

MAX BUILT-IN OVEN



MAX FUEGO INOX

In the photo:
Built in oven Max Fuego Inox
Finish: Lava stone Matrix
(GS02803)

TECHNICAL FEATURES

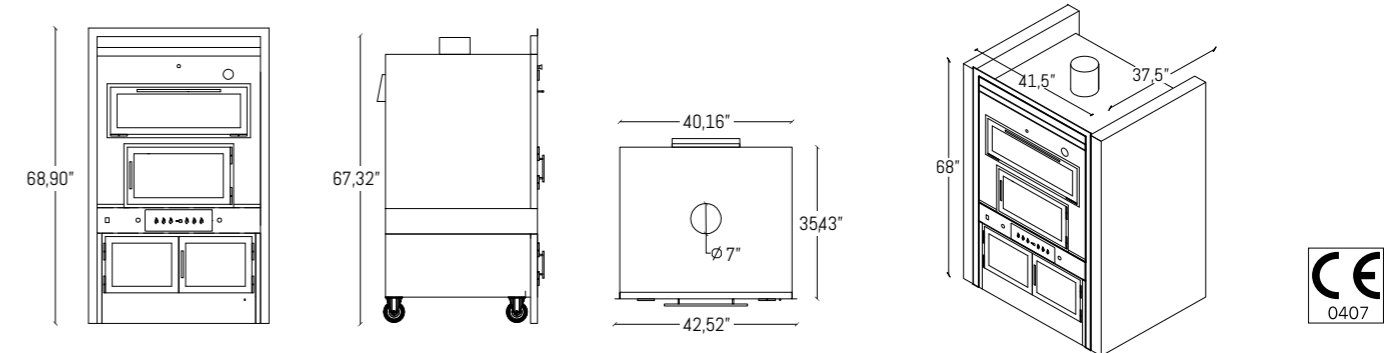

Cavity 105x95x173 cm (WxDxH)
41,34 x 37,40 x 68,11 inch (WxDxH)

COMBUSTIBLE	Dry wood
WOOD necessary to reach 250° C / 482 °F	6/8 kg - 13/17,5 lbs
WOOD necessary to maintain the temperature	2/2,5 kg - 4,5 / 5,5 lbs per hour
FLUE	Ø 18 cm / 7 inch
THERMAL POTENTIALITY	11,80 Kw / 10150 kcal/h
WEIGHT (depending on the coating)	400/500 kg - 880/1100 lbs
COMBUSTION CHAMBER	Terracotta tiles
COOKING CHAMBER	In stainless steel AISI 304
COOKING CHAMBER DIMENSIONS	78 x 75 cm - 30,7 x 29,53 inch
COOKING LEVELS	3
CAPACITY	8 kg / 17,5 lbs (bread baking)
EXTERNAL STRUCTURE	In stainless steel
INSULATION	In mineral wool
DOORS	In stainless steel with temperate glass
HANDLES	In brushed stainless steel with snap closure
ASH DRAWER	Sliding drawer with adjustable air intake
WHEELS AND REMOVABLE HANDLES	4 (to move the oven)
FOOD WARMER	Leaf door opening
ILLUMINATION OF THE COOKING CHAMBER	With halogen lamp 12V
VENTILATION OF THE COOKING CHAMBER	Airfan 12V