

# BUILT-IN OVEN

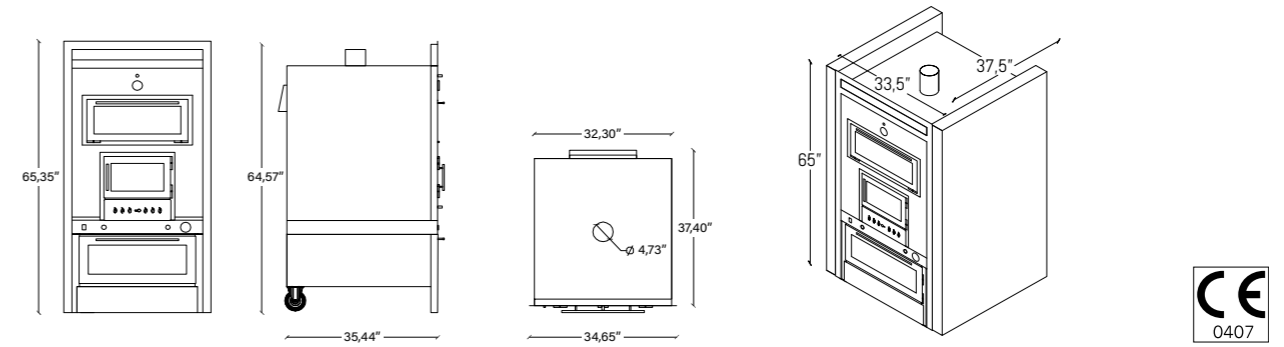

# TECHNICAL FEATURES



Cavity 85 x 95 x 165 cm (WxDxH)  
33,46 x 37,40 x 64,96 inch (WxDxH)

COMBUSTIBLE	Dry wood
WOOD necessary to reach 250° C / 482 °F	4/6 kg - 9/13 lbs
WOOD necessary to maintain the temperature	1/1,5 kg - 2,2 / 3,3 lbs per hour
FLUE	Ø 12 cm / 4,73 inch
THERMAL POTENTIALITY	9,69 Kw / 8336 kcal/h
WEIGHT (depending on the coating)	240/280 kg - 530/620 lbs
COMBUSTION CHAMBER	Terracotta tiles
COOKING CHAMBER	In stainless steel AISI 304
COOKING CHAMBER DIMENSIONS	54 x 75 cm - 21,25 x 29,53 inch
COOKING LEVELS	2
CAPACITY	5 kg / 11 lbs (bread baking)
EXTERNAL STRUCTURE	In stainless steel
INSULATION	In mineral wool
DOORS	In stainless steel with temperate glass
HANDLES	In brushed stainless steel with snap closure
ASH DRAWER	Sliding drawer with adjustable air intake
WHEELS AND REMOVABLE HANDLES	2 (for moving the oven)
FOOD WARMER	Sliding on wheels
ILLUMINATION OF THE COOKING CHAMBER	With halogen lamp 12V
VENTILATION OF THE COOKING CHAMBER	Airfan 12V

## FUEGO INOX

In the photo:  
Built-in oven Fuego Inox  
Covering: Medi Miele  
(MS02213)