

OUTDOOR OVEN WITH BARBECUE



FUEGO INOX

In the photo:
Outdoor oven Fuego Inox
with barbecue
Finish: Pietra a spacco
(MS03183 + BBQ03183)

TECHNICAL FEATURES

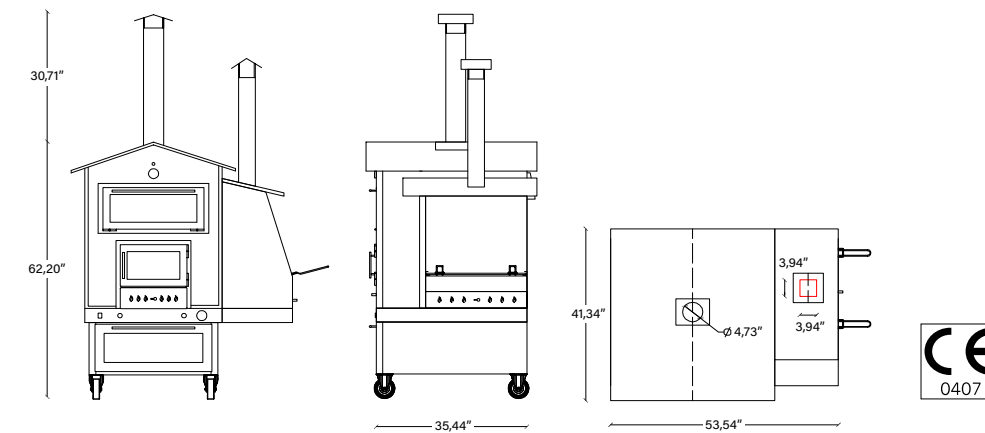

COMBUSTIBLE	Dry wood
WOOD necessary to reach 250° C / 482 °F	4/6 kg - 9/13 lbs
WOOD necessary to maintain the temperature	1/1,5 kg - 2,2 / 3,3 lbs per hour
FLUE	Ø 12 cm / 4,73 inch
THERMAL POTENTIALITY	9,69 Kw / 8336 kcal/h
WEIGHT (depending on the coating)	290/340 kg - 640/750 lbs
COMBUSTION CHAMBER	Terracotta tiles
COOKING CHAMBER	stainless steel AISI 304
COOKING CHAMBER DIMENSIONS	54 x 75 cm - 21,25 x 29,53 inch
COOKING LEVELS	2
CAPACITY	5 kg / 11 lbs (bread baking)
EXTERNAL STRUCTURE	In stainless steel
SLOPING ROOF AND FLUE	In stainless steel
INSULATION	In mineral wool
DOORS	In stainless steel with temperate glass
HANDLES	In brushed stainless steel with snap closure
ASH DRAWER	Sliding drawer with adjustable air intake
WHEELS AND REMOVABLE HANDLES	4 (to move the oven)
FOOD WARMER	Sliding on wheels
ILLUMINATION OF THE COOKING CHAMBER	With halogen lamp 12V
VENTILATION OF THE COOKING CHAMBER	Airfan 12V

BARBECUE

COMBUSTIBLE	Charcoal
FLUE	square flue dim. 10 cm / 3,94 inch
GRILL DIMENSIONS	60 x 40 cm - 23,62 x 15,75 inch in stainless steel
STRUCTURE	In stainless steel
ASH DRAWER	Sliding drawer with adjustable air intake
SLOPING ROOF AND FLUE	In stainless steel